

|    |  |
|----|--|
| DE | <b>Montageanleitung</b>                  |
| EN | Translation of the assembly instructions |
| FR | Traduction des instructions de montage   |
| IT | Traduzione delle istruzioni di montaggio |
| ES | Traducción del manual original           |
| NL | Vertaling van de montagehandleiding      |
| CZ | Překlad montážního návodu                |
| SK | Preklad návodu na montáž                 |
| PL | Tłumaczenie instrukcji montażu           |
| HU | Az összeszerelési útmutató fordítása     |



## Fahrerstandplattform GRD 500/R

55572

**Güde**



|                |  |
|----------------|--|
| DEUTSCH        | Bitte lesen Sie die Betriebsanleitung vor Inbetriebnahme sorgfältig durch.                       |
| ENGLISH        | Please read the instructions carefully before starting the machine.                              |
| FRANÇAIS       | Veillez lire avec soin le mode d'emploi avant la mise en service                                 |
| ITALIANO       | Leggere attentamente le istruzioni per l'uso prima di mettere in funzione l'elettrodomestico.    |
| ESPAÑOL        | Por favor, lea este manual de instrucciones detalladamente antes de la puesta en funcionamiento. |
| NEDERLANDS     | Graag instructies zorgvuldig doorlezen vóórdat u de machine in gebruik neemt.                    |
| ČEŠTINA        | Před spuštěním stroje si pečlivě přečtěte návod k používání.                                     |
| SLOVENČINA     | Pred prvým použitím prístroja si pozorne prečítajte návod na obsluhu.                            |
| POLSKI         | Przed przystąpieniem do uruchomienia prosimy o dokładne zapoznanie się z instrukcją obsługi.     |
| MAGYAR         | Kérk alaposan olvassa el a tájékoztatót mielőtt a gépet használja.                               |
| ΕΛΛΗΝΙΚΗ       | Διαβάστε προσεκτικά τις οδηγίες λειτουργίας πριν από τη θέση σε λειτουργία.                      |
| LIETUVIŲ KALBA | Prieš pradėdami eksploatuoti atidžiai perskaitykite naudojimo instrukciją.                       |



## **Montage**

**EN** Operation **FR** Fonctionnement **IT** Esercizio **ES** Operación  
**NL** Gebruik **CZ** Provoz **SK** Prevádzka **PL** Operacja **HU** Üzemeltetés  
**GR** Συναρμολόγηση **LT** Surinkimas



## Lieferumfang



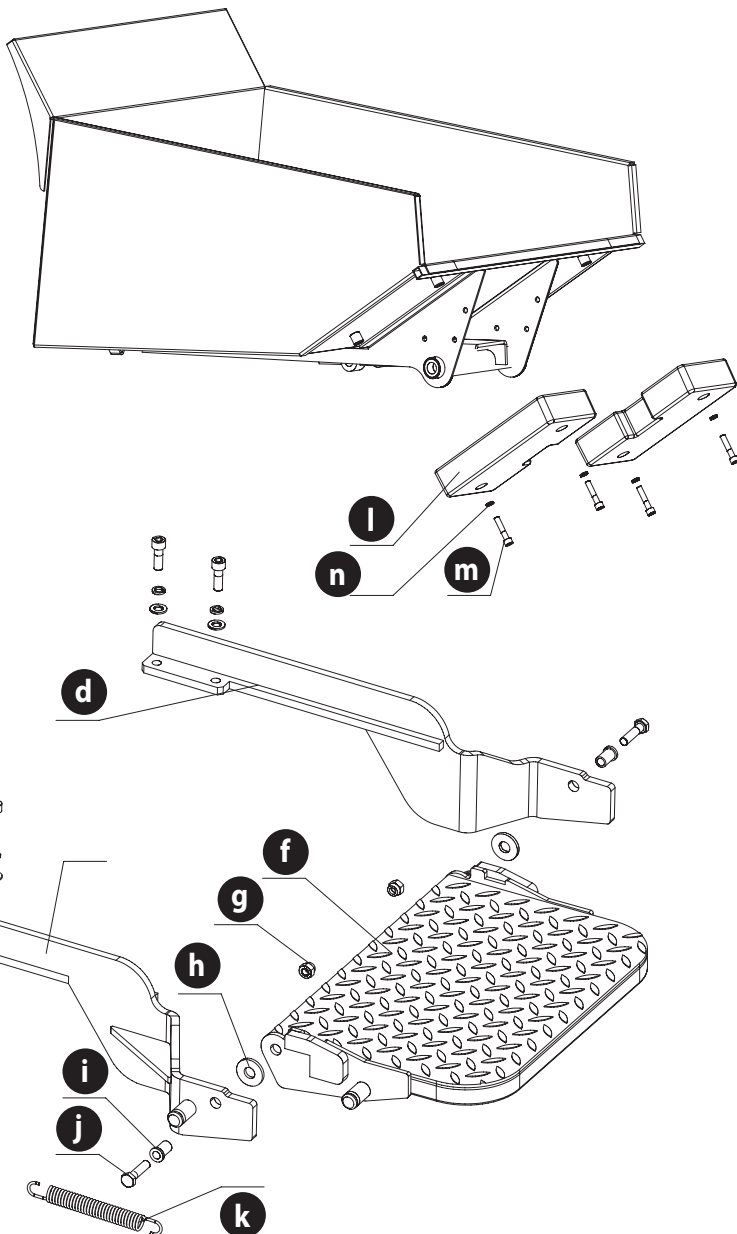

EN Scope of delivery FR Contenu de la livraison IT Dotazione  
ES Volumen de suministro NL Leveringsomvang CZ OBJEM dodávky  
SK Rozsah dodávky PL Zakres dostawy HU Szállítási terjedelem

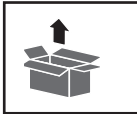

## Lieferumfang

EN Scope of delivery FR Contenu de la livraison IT Dotazione  
ES Volumen de suministro NL Leveringsomvang CZ OBJEM dodávky  
SK Rozsah dodávky PL Zakres dostawy HU Szállítási terjedelem



|                |   |    |                               |
|----------------|---|----|-------------------------------|
| <b>a b c</b>   |    | 1x | M10 x 30                      |
| <b>d</b>       | Right Conneting Part  | 1x |                               |
| <b>e</b>       | Left Conneting Part   | 6x | Axis Pin 10x60;<br>Cotter Pin |
| <b>f</b>       | Platform  | 1  |                               |
| <b>g h i j</b> |    | 2  | M10 x 40                      |
| <b>k</b>       |   | 1  | Spring                        |
| <b>l</b>       | Counter Weight  | 2  |                               |
| <b>m n</b>     |  | 4  | M10 x 25                      |



1

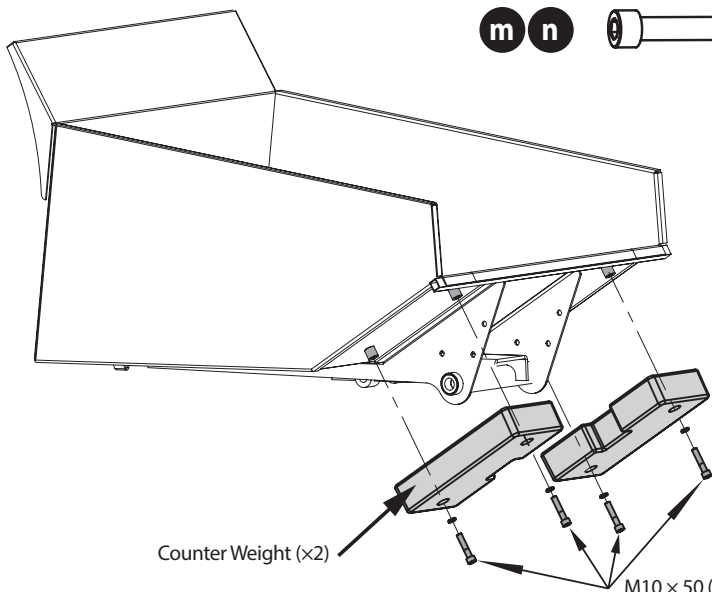
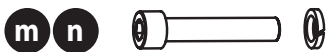

Counter Weight (x2)

M10 x 50 (x4)

2

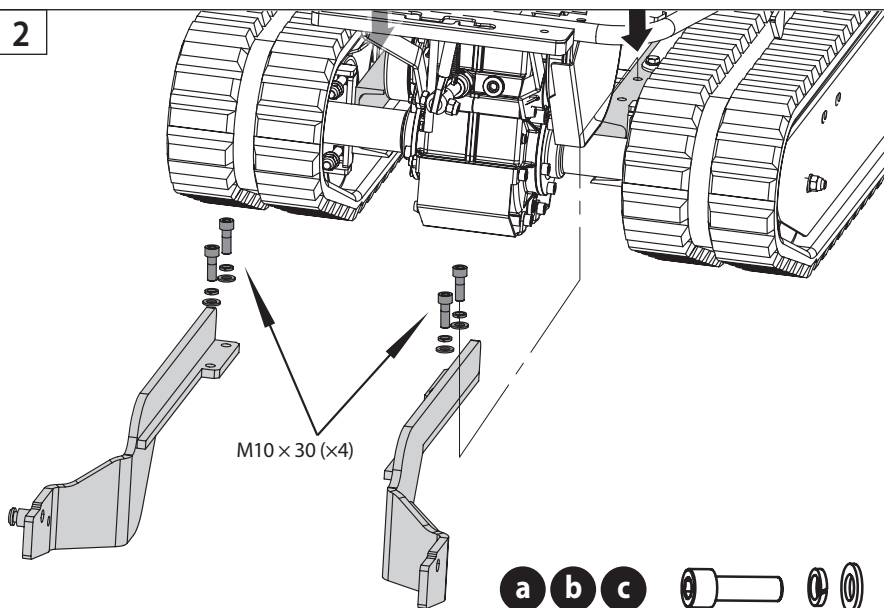

M10 x 30 (x4)



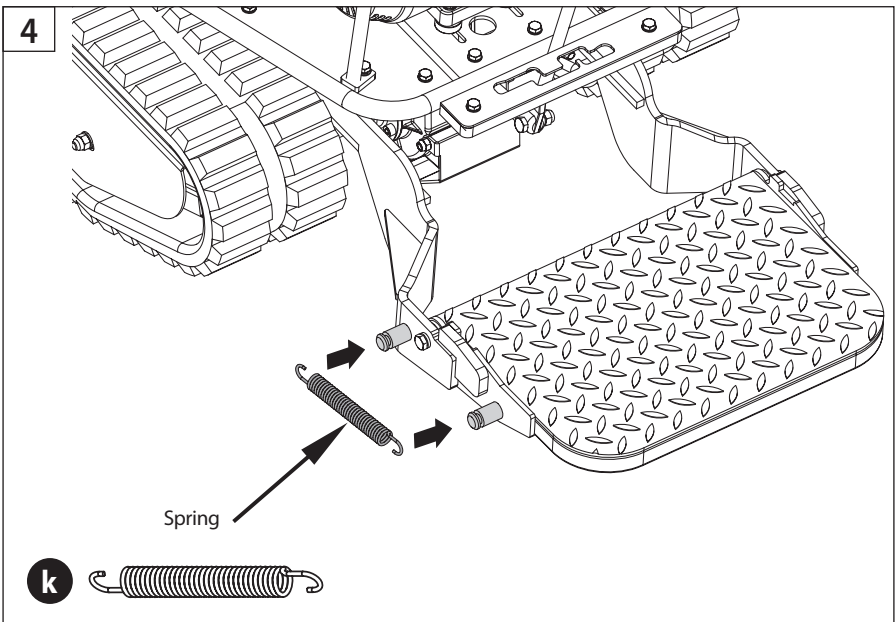
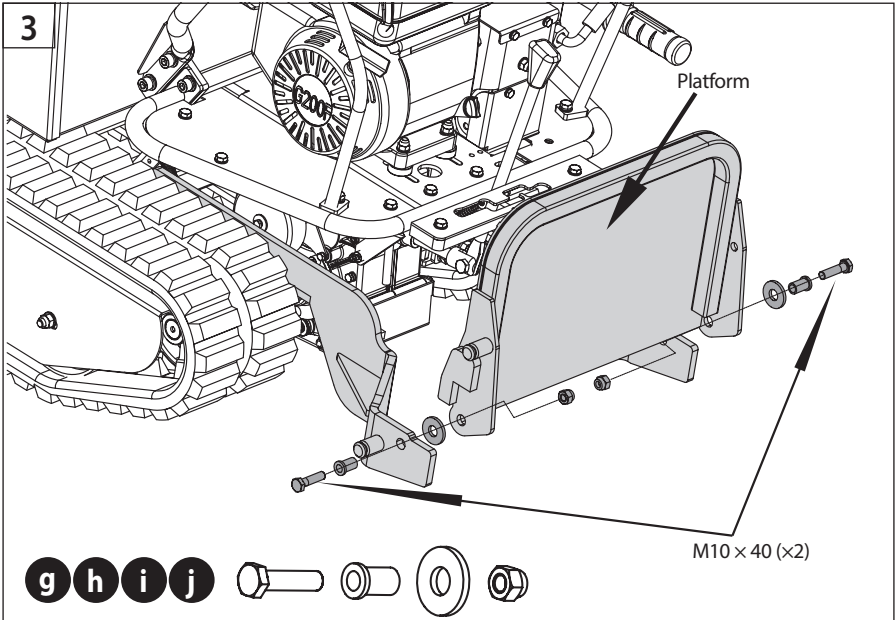

**GÜDE GmbH & Co. KG**

Birkichstrasse 6  
74549 Wolpertshausen  
Deutschland

Tel.: +49-(0)7904/700-0

Fax.: +49-(0)7904/700-250

eMail: [info@guede.com](mailto:info@guede.com)

[www.guede.com](http://www.guede.com)